

SERIES R101

1X4 and 1X8 Channel to Wrap
L Bracket Mounted
Pre-Wired RetroFit Assembly

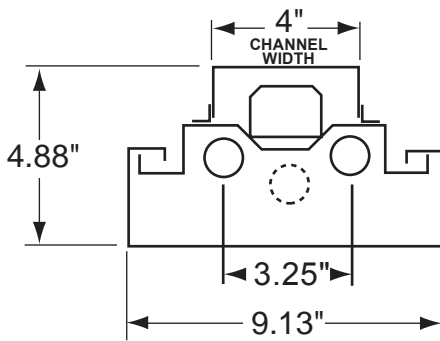
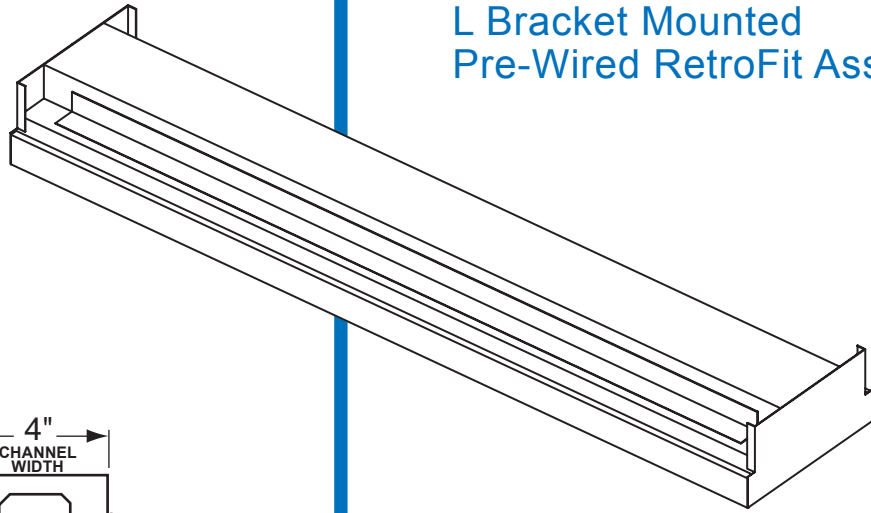

UNION MADE IN THE USA.

ORDERING:

NOMINAL SIZE	LAMPS	CATALOG NUMBER
1' X 4'	1-FO32	R101-148T8
1' X 4'	2-FO32	R101-248T8
1' X 8'	2-FO32	R101-148-2T8
1' X 4'	3-FO32	R101-348T8
1' X 8'	4-FO32	R101-248-2T8
1' X 8'	6-FO32	R101-348-2T8

INSERT VOLTAGE AT END OF CATALOG NUMBER

FEATURES:

- CONVERT EXISTING COMMERCIAL STRIP TO A SURFACE MOUNTED WRAP STYLE FIXTURE
- ACRYLIC PRISMATIC HOOK-ON LENS CANNOT BE ACCIDENTALLY DISLODGED
- PROVIDES ABILITY TO MAINTAIN CURRENT LIGHTING LAYOUT WHILE CHANGING THE FIXTURE LOOK
- QUICK INSTALLATION REDUCES LABOR COSTS
- POST PAINTED HIGH REFLECTANCE POWDER COAT FINISH

NOTES:

1. DESIGNED TO FIT 3-3/4 INCH TO 7-1/2 INCH WIDTH OPEN COMMERCIAL CHANNELS

MANUFACTURING
1715 KIBBY ROAD - MERCED - CALIFORNIA - 95340
(209) 723-9120 - FAX: (209) 723-9131

SALES OFFICE
14722 WICKS BLVD. - SAN LEANDRO - CALIFORNIA - 94577-6718
(510) 667-6950 - FAX: (510) 667-6959

INSTALLATION INSTRUCTIONS

INSTALLER TO INSURE THAT VOLTAGE OF RETROFIT ASSEMBLY IS THE SAME VOLTAGE AS THE UNIT TO BE RETROFITTED.

INSTALLER INSURE THAT WIDTH OF HOUSING IS BETWEEN 3-3/4" AND 7-1/2".

TURN OFF POWER TO FIXTURE BEING RETROFITTED.

REMOVE EXISTING LAMPS.

REMOVE EXISTING BALLAST/WIREWAY COVER(S).

CUT BALLAST BLACK & WHITE LEADS WITHIN 8 TO 9 INCHES OF BRANCH CIRCUIT CONDUCTORS.

REMOVE EXISTING LAMP HOLDERS, SOCKET PLATES AND END CAPS.

REMOVE BALLAST AND DISCARD IN ACCORDANCE WITH LOCAL CODES AND/OR HAZARDOUS MATERIAL REQUIREMENTS.

ATTACH MOUNTING ANGLES USING PROVIDED "TEK" SCREWS. INSURE BRACKET IS APPROXIMATELY 1 INCH FROM THE END (USE YOUR THUMB AS A GUIDE).

CONNECT THE POWER SUPPLY WIRES TO THE BLACK AND WHITE LEADS ON THE RETROFIT ASSEMBLY BALLAST USING PROVIDED WIRE NUTS. CONNECT BLACK TO BLACK AND WHITE TO WHITE.

USING THE PROVIDED "TEK" SCREWS SECURE RETRO-KIT TO THE MOUNTING BRACKETS BY SCREWING THROUGH THE HOUSING SLOTS.

ONCE RETROKIT IS INSTALLED ATTACH END PLATE AND SECURE WRAPAROUND LENS.

INSTALL LAMPS AND TURN ON POWER.

NOTE

All fixtures must be installed, wired and grounded in accordance with the National Electric Code and all other applicable codes.

!!! WARNING !!!

RISK OF FIRE OR ELECTRICAL SHOCK. ELECTRICAL PARTS MAY BE DAMAGED WHEN DRILLING OR USING "TEK" SCREWS FOR INSTALLATION OF MOUNTING HARDWARE. CHECK ENCLOSED WIRING AND COMPONENTS. USE CAUTION WHEN DRILLING "TEK" SCREWS INTO A BLIND AREA. TO PREVENT WIRING DAMAGE DO NOT EXPOSE WIRING TO SHARP EDGES.

